

SMALL HYDRAULIC PORTABLE TEST UNIT

CODE	MA.W.P.(bar)	AIR CONN.	INLET CONN.	HP CONN.	GAUGE RANGE	STROKE VOLUME
SHPTU-070	490 bar	1/4" GAS	1/2" GAS	1/2" NPT	0:600 bar	3,4 CM ³
SHPTU-100	700 bar	1/4" GAS	1/2" GAS	3/8" MP	0:1000 bar	2,4 CM ³
SHPTU-150	1050 bar	1/4" GAS	1/2" GAS	3/8" HP	0:1600 bar	1,5 CM ³
SHPTU-270	1890 bar	1/4" GAS	1/2" GAS	3/8" HP	0:2000 bar	0,8 CM ³
SHPTU-300	2100 bar	1/4" GAS	1/2" GAS	3/8" HP	0:3000 bar	1,5 CM ³
SHPTU-540	3780 bar	1/4" GAS	1/2" GAS	3/8" HP	0:4000 bar	0,8 CM ³

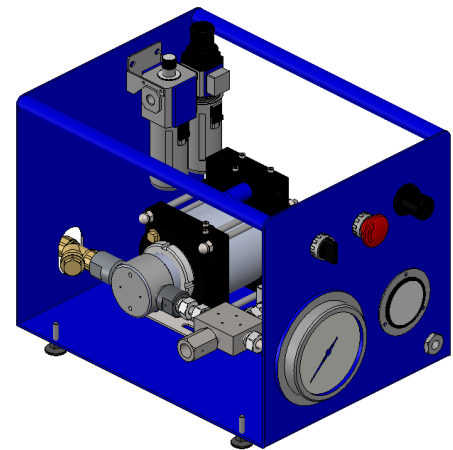

STANDARD OPTION
HIGH PRESSURE DISCHARGE VALVE
PUMP PRESSURE AIR REGULATOR AND GAUGE
AIR FILTER AND AIR LUBBRICATOR
INLET FILTER
CE MARKING
WATER INLET BALL VALVE
WATER SERVICE
START – STOP VALVE

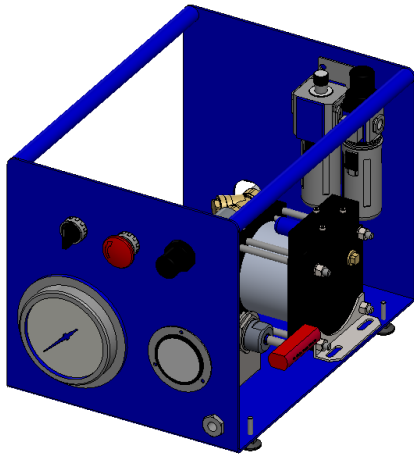
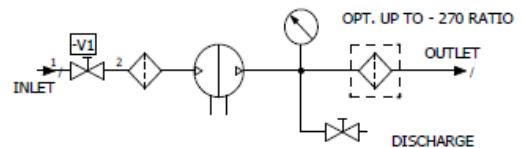

STANDARD FEATURE
MAX AIR CONSUMPTION 300 NL/MIN
AIR SUPPLY 1,5 - 7 BAR
HYDRAULIC SUPPLY 1 - 3 BAR
DISCHARGE CONNECTION 1/4" GAS
WEIGHT 20 KG (APPROX)
MAIN GAUGE SIZE 100 MM

